

STERN® Austria

IMPACT DRILL ID13L

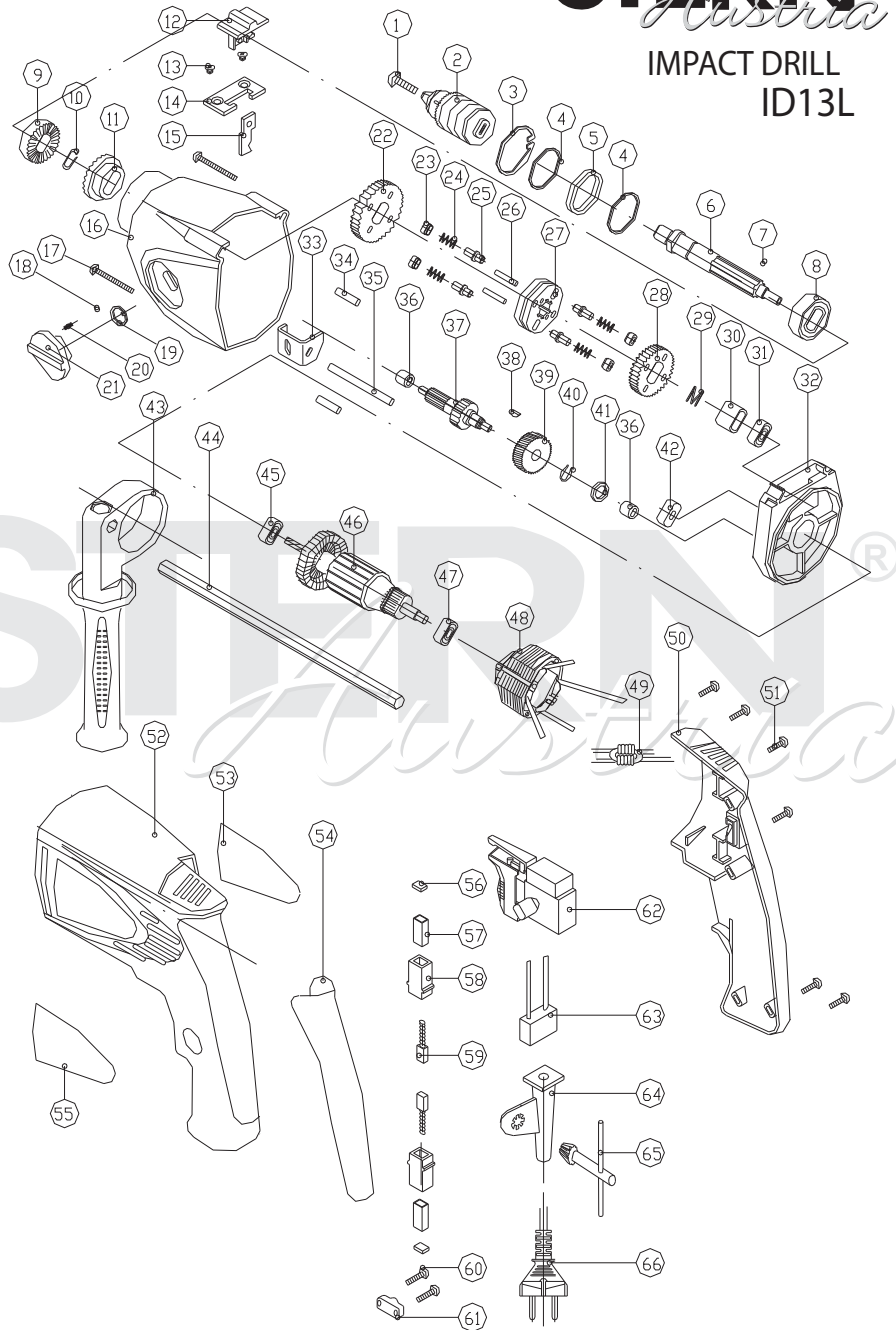

STERN® IMPACT DRILL Austria ID13L

NO.	DESCRIPTION	NO.	DESCRIPTION
1	CHUCK SCREW	34	POSITIONING PIN
2	DRILL CHUCK	35	SHIFTING FORK PIN
3	CIRCLIP FOR SHAFT 1	36	NEEDLE BEARING HK0709
4	BIG WASHER	37	MIDDLE SHAFT
5	SEAL LOOP	38	WOODRUFF KEY
6	OUTPUT SHAFT	39	GEAR3
7	STEEL BALL	40	CIRCLIP FOR SHAFT
8	BEARING 6003Z	41	SMALL WASHER
9	IMPACT BLOCK1	42	SEALING RING
10	CIRCLIP FOR SHAFT 2	43	AUXILIARY HANDLE
11	IMPACT BLOCK2	44	DEPTH GAUGE
12	IMPACT/ DRILL SHIFT BUTTON	45	BEARING 608Z
13	SCREW	46	ROTOR
14	FIX SEAT	47	BEARING 607Z
15	SHIFTING PLATE	48	STATOR
16	GEAR BOX	49	INDUCTOR
17	SCREW	50	RIGHT HANDLE
18	STEEL BALL 4	51	TAPPING SCREW
19	CIRCLIP FOR SHAFT 3	52	HOUSING
20	SPRING1	53	TRADEMARK
21	REGULATING KNOB	54	HANDLE COVER
22	GEAR1	55	TRADEMARK
23	COVER	56	BRUSH CAP
24	SPRING2	57	BRUSH BUSH
25	TRANSMISSION PIN	58	BRUSH HOLDER
26	PIN	59	CARBON BRUSH
27	SLIP RING	60	SCREW
28	GEAR2	61	CABLE CLAMP
29	SPRING3	62	SWITCH
30	BUSH	63	CAPACITOR
31	BEARING 608Z	64	CABLE SLEEVE
32	MIDDLE COVER	65	CHUCK KEY
33	SHIFTING FORK	66	CORD & PLUG